

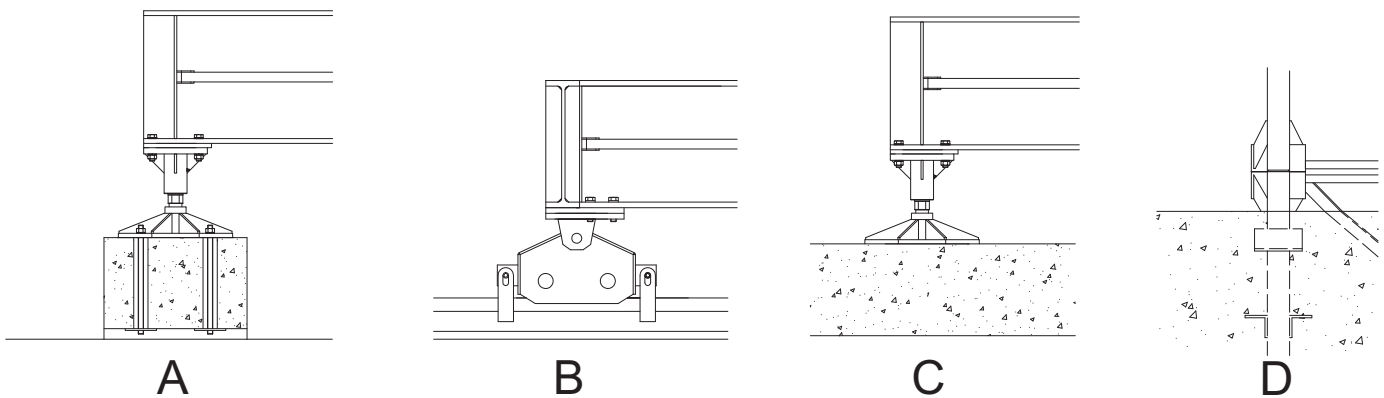

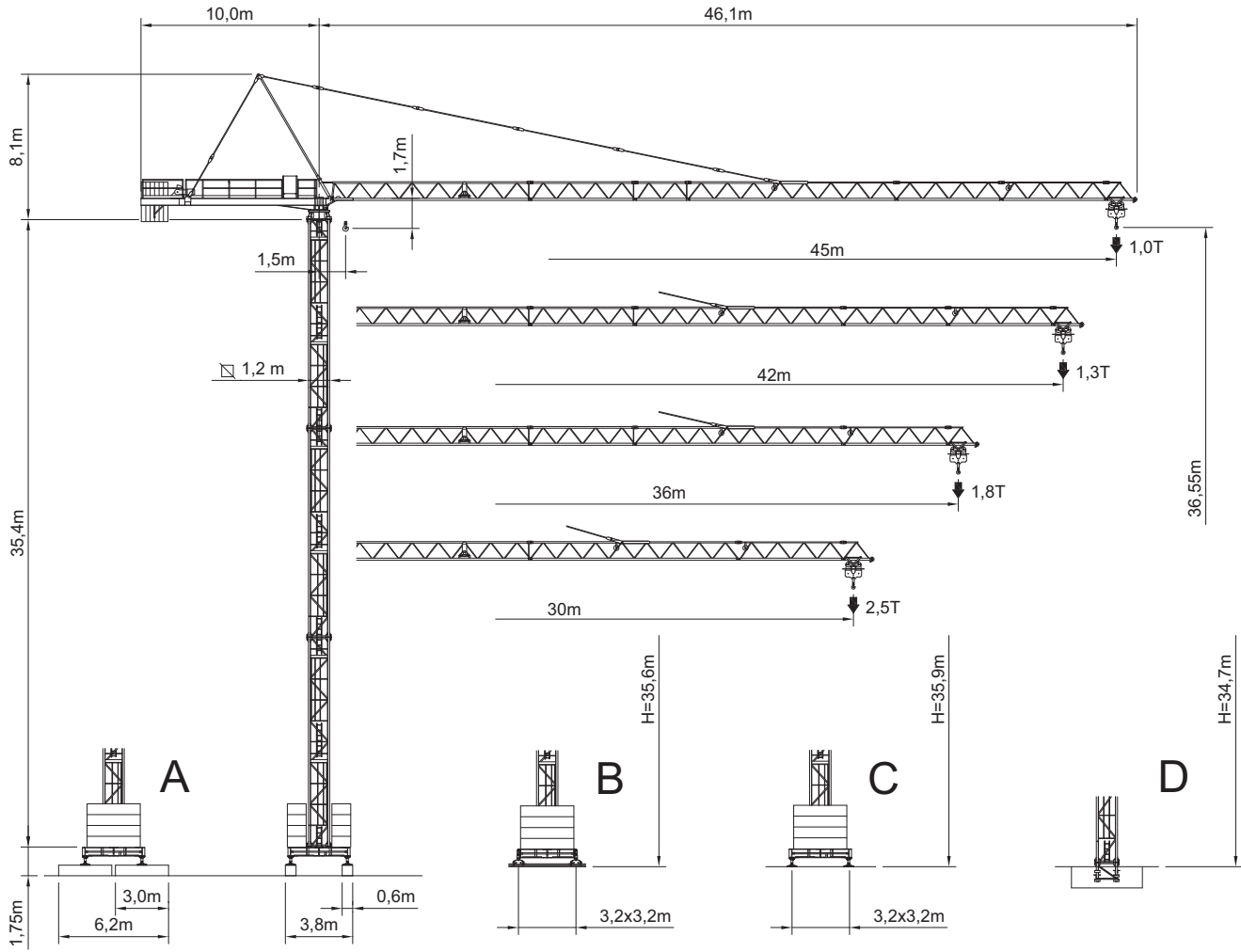

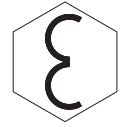

City Crane MR 66E

GRU A TORRE A MONTAGGIO RAPIDO
«CITY TOWER CRANE»



RAGGI E PORTATE
RADIUS AND S.W.L.
PORTEE ET CHARGE UTILE
AUSLADUNG UND TRAGFAHIGKEIT

| Portata max / Max s.w.l. Charge maxi / Max. Tragfähigkeit | | 2500 kg.  | | | | 3000 kg.  | | | | 4000Kg   / 2000 kg.  | | | |
|--|---------------------------|--|------|------|------|---|------|------|------|---|------|------|------|
| Braccio / Jib Ausleger / Flèche | m. | 30 | 36 | 42 | 45 | 30 | 36 | 42 | 45 | 30 | 36 | 42 | 45 |
| Campo di portata max da Max s.w.l. range from Charge maxi de Max. Tragfähigkeit von | 1,5 m a to à bis | 30 | 26,9 | 23,9 | 21,2 | 25,5 | 23,2 | 20,7 | 18,0 | 19,7 | 17,9 | 16,0 | 14,0 |
| Raggi (m.) Radii (m.) Portée (m.) Ausladung (m.) | 12 | 2500 | 2500 | 2500 | 2500 | 3000 | 3000 | 3000 | 3000 | 4000 | 4000 | 4000 | 4000 |
| | 14 | 2500 | 2500 | 2500 | 2500 | 3000 | 3000 | 3000 | 3000 | 4000 | 4000 | 4000 | 4000 |
| | 16 | 2500 | 2500 | 2500 | 2500 | 3000 | 3000 | 3000 | 3000 | 4000 | 4000 | 4000 | 3450 |
| | 18 | 2500 | 2500 | 2500 | 2500 | 3000 | 3000 | 3000 | 3000 | 4000 | 3910 | 3460 | 3018 |
| | 20 | 2500 | 2500 | 2500 | 2500 | 3000 | 3000 | 3000 | 2675 | 3860 | 3460 | 3050 | 2675 |
| | 22 | 2500 | 2500 | 2500 | 2396 | 3000 | 3000 | 2790 | 2396 | 3460 | 3100 | 2730 | 2396 |
| | 24 | 2500 | 2500 | 2460 | 2166 | 3000 | 2880 | 2460 | 2166 | 3130 | 2800 | 2460 | 2166 |
| | 26 | 2500 | 2500 | 2310 | 1971 | 2940 | 2630 | 2310 | 1971 | 2850 | 2540 | 2230 | 1971 |
| | 28 | 2500 | 2400 | 2110 | 1806 | 2690 | 2400 | 2110 | 1806 | 2610 | 2320 | 2030 | 1806 |
| | 30 | 2500 | 2230 | 1950 | 1662 | 2500 | 2230 | 1950 | 1662 | 2400 | 2140 | 1870 | 1662 |
| | 32 | | 2060 | 1815 | 1537 | | 2060 | 1815 | 1537 | | 1970 | 1720 | 1537 |
| | 34 | | 1920 | 1680 | 1427 | | 1920 | 1680 | 1427 | | 1830 | 1590 | 1427 |
| | 36 | | 1800 | 1570 | 1330 | | 1800 | 1570 | 1330 | | 1700 | 1480 | 1330 |
| | 38 | | | 1470 | 1243 | | | 1470 | 1243 | | | 1370 | 1243 |
| | 40 | | | 1380 | 1165 | | | 1380 | 1165 | | | 1280 | 1165 |
| 42 | | | 1300 | 1094 | | | 1300 | 1094 | | | 1200 | 1094 | |
| 45 | | | | 1000 | | | | 1000 | | | | 1000 | |

BRACCIO E CONTRAPPESO
JIB AND COUNTERWEIGHT
FLECHE ET CONTREPOID
AUSLEGER UND GEGENGEWICHTSBALLAST

| | | | | | |
|--|-------------|---------------------------------------|-------|-------|-------|
| Braccio / Jib Flèche / Ausleger | (m) | 30 | 36 | 42 | 45 |
| Contrappeso / Counterweight Contrepoid / Gegengewicht | (t) | 5,800 | 7,250 | 8,700 | 9,150 |
| Composizione Composition Komposition | Tipo / Type | Quantità / Quantity / Nombre / Anzahl | | | |
| | AH | 4 | 5 | 6 | 6 |
| | AH1 | - | - | - | 1 |

ALTEZZA SOTTO-GANCIO, ZAVORRA DI BASE, REAZIONI
 H.U.H., MAX. BASE BALLAST AND CORNER PRESSURE
 H.S.C., LEST DE BASE MAXI ET REACTIONS
 HAKENHOHEN, MAXIMALE ZENTRALBALLASTE UND ECKKRAFT

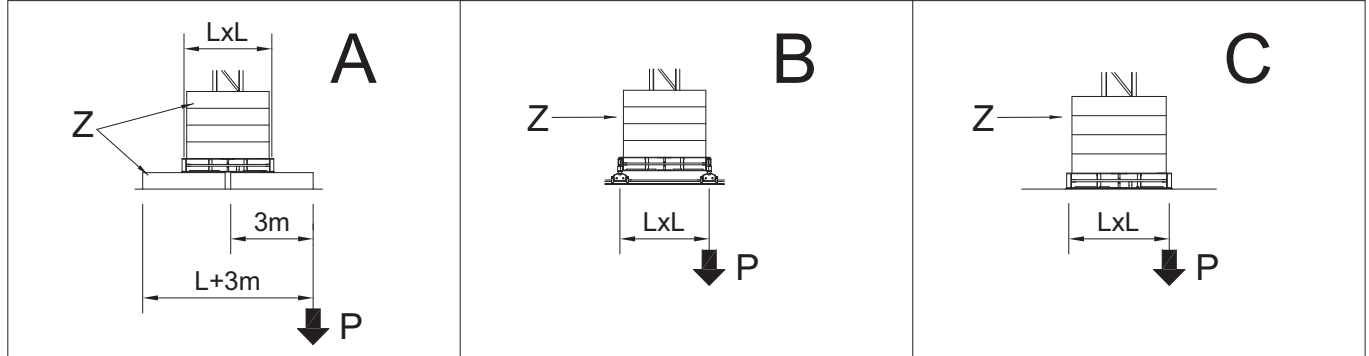





| SU BASE / ON CROSSBASE SUR CHASSIS / AUF KREUZRAHME | | | | | | | | |
|--|------------|--------|-------|------------|--------|-------|------------|--------|
| L = 3,8 m (□ 1,2m) | | | | | | | | |
| H (m) | max. Z (t) | P (kN) | H (m) | max. Z (t) | P (kN) | H (m) | max. Z (t) | P (kN) |
| 40,2 | 49,5 | 523 | 39,8 | 49,5 | 522 | 39,4 | 49,5 | 505 |
| 36,2 | 49,5 | 414 | 35,8 | 49,5 | 413 | 35,4 | 49,5 | 397 |
| 30,3 | 49,5 | 336 | 29,9 | 49,5 | 339 | 29,5 | 49,5 | 334 |
| 24,4 | 39,6 | 290 | 24,0 | 39,6 | 293 | 23,6 | 39,6 | 289 |
| 18,5 | 39,6 | 273 | 18,1 | 39,6 | 275 | 17,7 | 39,6 | 271 |

| SU BASE / ON CROSSBASE SUR CHASSIS / AUF KREUZRAHME | | | | | | | | |
|--|------------|--------|-------|------------|--------|-------|------------|--------|
| L = 3,2 m (□ 1,2m) | | | | | | | | |
| H (m) | max. Z (t) | P (kN) | H (m) | max. Z (t) | P (kN) | H (m) | max. Z (t) | P (kN) |
| 36,0 | 49,5 | 493 | 35,6 | 49,5 | 489 | 35,2 | 49,5 | 483 |
| 30,1 | 49,5 | 363 | 29,7 | 49,5 | 365 | 29,3 | 49,5 | 362 |
| 24,2 | 49,5 | 338 | 23,8 | 44,5 | 329 | 23,4 | 44,5 | 325 |
| 18,3 | 49,5 | 318 | 17,9 | 44,5 | 309 | 17,5 | 44,5 | 305 |
| 12,4 | 39,6 | 277 | 12,0 | 39,6 | 280 | 11,6 | 39,6 | 277 |

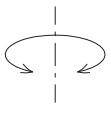
SU PLINTO / STATIONARY
 SUR PIEDS DE SCELLEMENT / STATIONAR

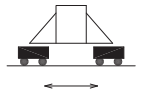
| | H (m) | 11,1 | 17,0 | 22,9 | 28,8 | 34,7 | 38,7 |
|--|-----------------|------|------|------|------|------|------|
| | T (kN) | 313 | 348 | 394 | 452 | 612 | 798 |
| | P (kN) | 411 | 453 | 505 | 570 | 740 | 930 |
| | q max. (Kg/cm²) | 0,87 | 0,94 | 1,04 | 1,16 | 1,69 | 2,53 |

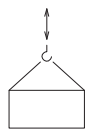









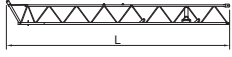

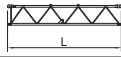



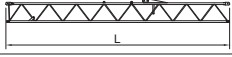









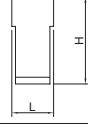

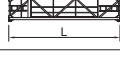





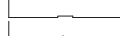

| | | Velocità / Speed / Vitesse / Geschwindigkeit | Potenza / Power / Puissance / Leistung |
|--|---|--|--|
| Rotazione Slewing Orientation Schwenken |  | 0,35 / 0,62 / 0,94 min ⁻¹ | 4,0 Kw |
| Carrello Trolley Chariot Katzfahren |  | 28,5 / 57 m/min | 1,1/2,2Kw |
| Traslazione Rail Translation Kranfahren |  | 14 m/min | 2 x 2,9 Kw |

| Argano Winch Treuril Hubwerk |  | Marcia Step Vitesse Gang | Carico / velocità - Load / speed Charge / vitesse - Tragfähigkeit / Geschwindigkeit | |
|---------------------------------------|---|-----------------------------------|--|---|
| | | |  |  |
| Tipo Type Type Typ | 15 HP 11 Kw - 2,5 | 1 | 2500 Kg - 5,2 m/min | - |
| | | 2 | 2500 Kg - 21 m/min | - |
| | | 3 | 1250 Kg - 42 m/min | - |
| | 25 HP 18,4 Kw - 3 | 1 | 3000 Kg - 7,5 m/min | - |
| | | 2 | 3000 Kg - 30 m/min | - |
| | | 3 | 1500 Kg - 60 m/min | - |
| | 15 HP 11 Kw - 4 | 1 | 2000 Kg - 6,7 m/min | 4000 Kg - 3,4 m/min |
| | | 2 | 2000 Kg - 27 m/min | 4000 Kg - 13,5 m/min |
| | | 3 | 1000 Kg - 54 m/min | 2000 Kg - 27 m/min |

Conforme alla direttiva CEE 85/534 sul livello acustico - In compliance with the EEC 84/534 instruction on noise level - Conforme à directive CEE 84/534 sur le niveau acoustique
Gemäss EWG 84/534 über Schall - Leistungspegel - Conforme con la direttiva CEE 84/534 sobre el nivel acustico.

| | | |
|---|--------------|----------------|
| FORZA MOTRICE TOTALE TOTAL INSTALLED POWER PUISSANCE TOTALE DES MOTEURS GESAMT-MOTORENLEISTUNG | 11 Kw (15HP) | 18,4 Kw (25HP) |
| | 23 Kw | 31 Kw |

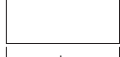
LISTA DEI PESI / PACKING LIST
LISTE DE COLISAGE / KOLLI-LISTE

| Pos. Item | Pezzi Pieces | Denominazione Description | Schizzo Sketch | Dimensioni Dimensions | | | Peso Weight (Kg) | | | |
|-----------|--------------|--|---|---|---|--------|------------------|--------|-------|-----|
| | | | | L | W | H | Unit. | Total. | | |
| 1 | 1 | Elemento di freccia Jib element Elément de flèche Ausleger | N°1 |  |  | 12,005 | 1,100 | 1,295 | 885 | |
| | 1 | | N°2 |  |  | 6,090 | 1,100 | 1,100 | 410 | |
| | 1 | | N°2A |  |  | 3,130 | 1,100 | 1,100 | 233 | |
| | 1 | | N°3 |  |  | 12,010 | 1,100 | 1,100 | 880 | |
| | 2 | | N°4-5 |  |  | 6,160 | 1,100 | 1,100 | 370 | 740 |
| | 1 | | N°6 |  |  | 1,850 | 1,100 | 1,100 | 120 | |
| 2 | 1 | Cuspide A frame Pointe Turmspitze |  |  | 6,750 | 0,400 | 0,950 | 385 | | |
| 3 | 1 | Controfreccia girevole, argano sollev., quadro elettrico, carrello freccia. Counterjib-turntable, hoisting winch, trolley jib, electrical box. Contreflèche tournante, treuil de levage, chariot de flèche, armoire électrique. Gegenausleger, Hubwinde, Drehwerk Laufkatze, Schaltschrank. |  |  | 11,970 | 1,540 | 2,340 | 5000 | | |
| 4 | 6 | Blocchi di contrappeso Counterweight block Contre-poids Gegengewichtsbloecke (AH) |  |  | 1,250 | 0,250 | 2,220 | 1450 | 8700 | |
| 5 | 1 | Elemento di torre Tower element Elément de mature Turmstück |  |  | 5,900 | 1,200 | 1,380 | 1515 | 1515 | |
| | | |  |  | 11,800 | 1,200 | 1,380 | 2830 | 2830 | |
| 6 | 1 | Tronchetto di fondazione Expendable foundation element Elément a sceller Fundamentanker |  |  | 1,350 | 1,490 | 1,490 | 730 | | |
| 7 | 1 | Trave principale della crociera di base Base main beam Poutre de chassis de base Hauptträger für Kreuzgelenk |  |  | 4,680 | 0,670 | 0,560 | 1020 | | |
| 8 | 2 | Semitrave della crociera di base Half base beam Semipoutre de chassis de base Halbträger für Kreuzgelenk |  |  | 2,270 | 0,450 | 0,590 | 535 | 1070 | |
| 9 | 4 | Blocco di appoggio Concrete pad Sabot en béton Betonfuss (B1) |  |  | 3,000 | 0,600 | 0,600 | 2465 | 9860 | |
| 10 | 2 | Bilancino traslazione folle Driven bogie Boggie fou Fahrschemel ohne motorantrieb |  |  | 0,800 | 0,195 | 0,385 | 190 | 380 | |
| 11 | 2 | Bilancino traslazione motorizzato Driving bogie Boggie motorisée Fahrschemel mit motorantrieb |  |  | 0,925 | 0,425 | 0,385 | 310 | 620 | |
| 12 | 10 | Blocco di zavorra Base ballast block Lest de base Grundballastblöcken (A) |  |  | 3,000 | 1,200 | 0,600 | 4953 | 49530 | |

SEQUENZA DI MONTAGGIO
ASSEMBLING SEQUENCE
SEQUENCE DE MONTAGE
AUFSTELLUNG SEQUENZ

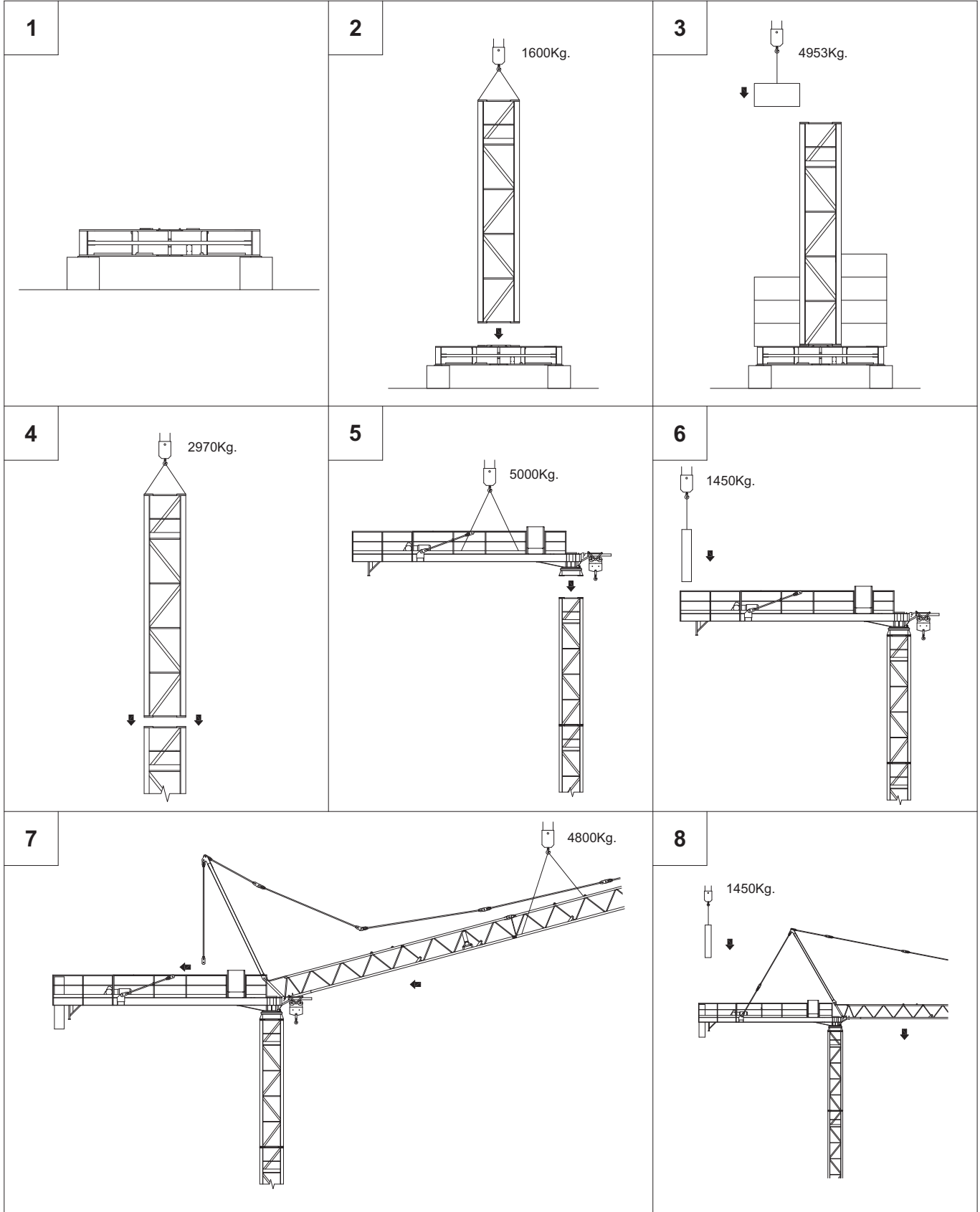

MR 66HC

A SOPRALZO IDRAULICO
EXTERNAL CLIMBING
TELESCOPABLE
KLETTERKRANE

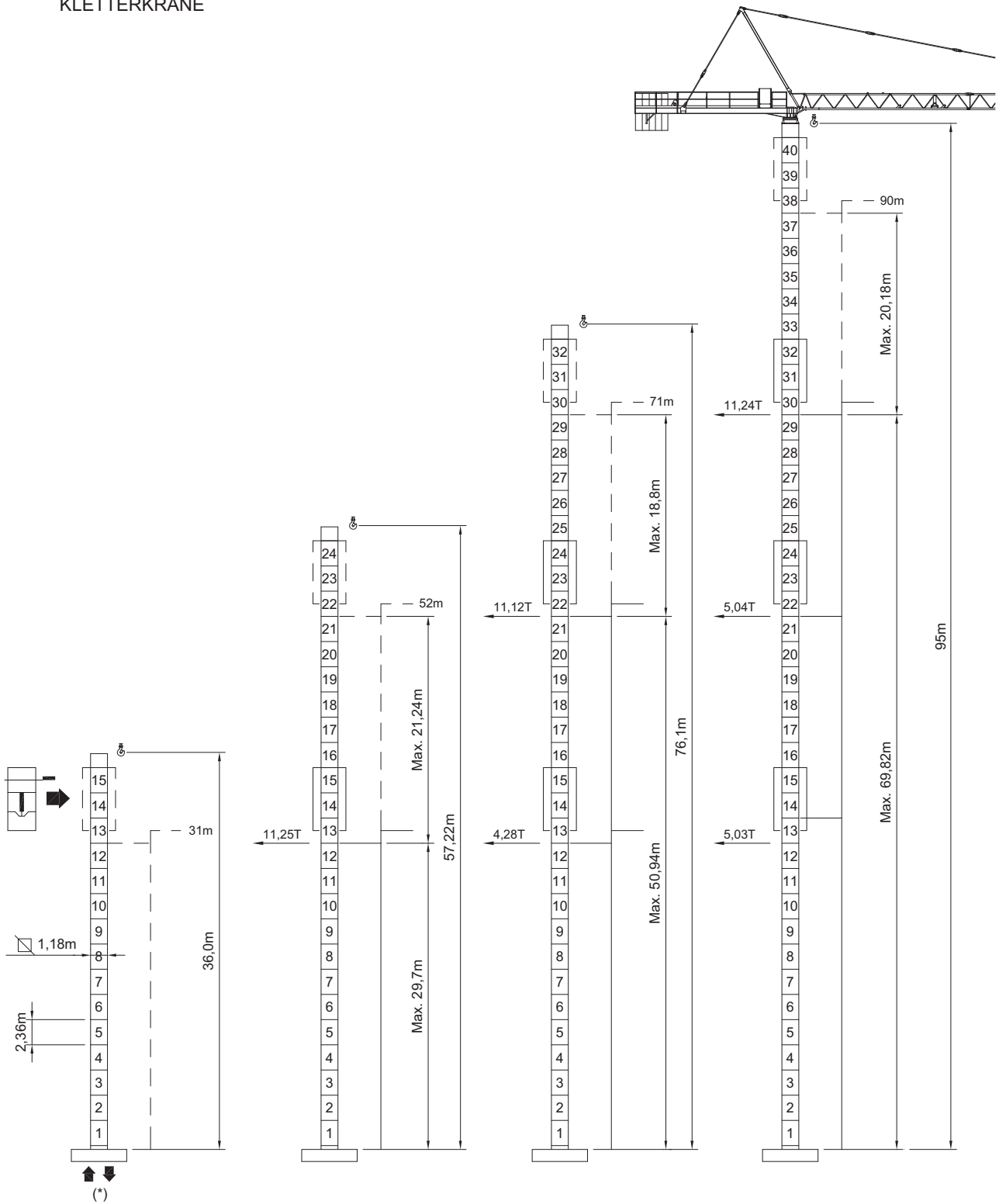

* Vedi tabella a pag. 4 - See table at page 4 - Voir table à la page 4 - Siehe tafel an seite 4

CARLO RAIMONDI S.p.A

Gru a torre per l'edilizia
Building tower cranes
Grues tour
Turmdrehkrane



Stabilimento:
Corso Garibaldi 253 - 20025 Legnano (MI) - ITALY - Fax: 0331450400 - Tel. 0331548061 - 0331545308 - www.raimondigr.it